

HI TOP TRACTOR
HD FV2447

6x4 • AMT



Power/Torque:
346kW / 2,227Nm



Wheelbase:
3,860mm (J)



Suspension:
Air

- 30,000km service intervals
- 7.5T tare weight
- Non-synchromesh transmission
- Isringhausen driver's seat

SPECIFICATIONS - FV2447 HI TOP TRACTOR

MODEL

6x4 HD FV2447

12 SP. AMT AIR SUSP.

FV54SJR5VFAB

WHEELBASE (mm)

3,860 (J)

GVM (kg)

24,000

GCM (kg)

60,000

ENGINE

Engine Version	FUSO OM457-T5 Diesel
Configuration	6 Cyl. In-line OHV
Type	Waste-gate Turbocharged with Air to Air Intercooled
Displacement	12 litre (11967cc)
Power (DIN)	335kW @ 1900rpm
Torque (DIN)	2,200Nm @ 1100rpm
Power (JIS Gross)*	346kw (470ps) @1900rpm
Torque (JIS Gross)*	2,227Nm (1644lbft) @1100rpm
Maximum Engine Speed (rpm)	2200
Cooling System / Oil Cooler	Water cooled with Viscous fan, 32.0L capacity. Engine oil cooler
Air Cleaner	Paper Element Type with Restrictor Indicator. Vertical Intake Mounted on Clean Air Side (RH)
Cold Start Preheat	Standard
Emission Control	Selective Catalytic Reduction (SCR)
Emission Level	Euro 5 (ADR 80/03)

*Calculated

OM457-T5

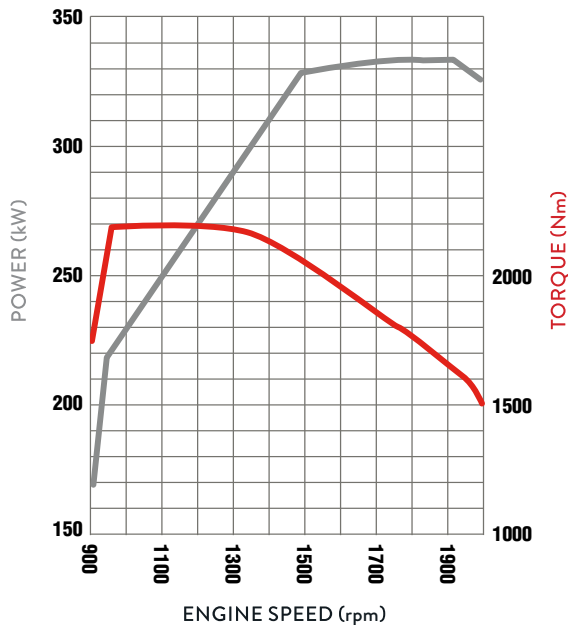

FUEL

Injection System	Electronically Controlled Unit Pump Injection
Tank Type	Rectangular Steel Tank with Locking Cap
Fuel Capacity (L)	350
Filtration	Filter with Water Separator and Dash Indicator
AdBlue Exhaust Fluid Capacity (L)	40 (Tank fitted with locking AdBlue cap)

ELECTRICAL

Voltage	24V Negative Ground
Alternator Capacity	24V-80 amp
Battery Specification	Heavy Duty 2 x 12V, 150Ah / 20hr
Headlamp Type	Halogen 2 x 70W / 70W
Fog Light	Halogen

CLUTCH

Clutch Model	FUSO C12W43P
Type	Single Plate
Operation/Specification	Automated Manual (no clutch pedal)

TRANSMISSION

Version	FUSO Automated Manual G330-12 (INOMAT-II)	
Type/Speeds	12 Speed AMT with Auto and Manual Modes Constant Mesh Non Synchronesh Transmission	
Features	Crawler Mode Skip Shift Function for Light Loads ECO Mode to Minimise Fuel Usage Start gear select. Reverse Hi / Low	
Ratios	1st: 11.639 2nd: 9.020 3rd: 7.035 4th: 5.452 5th: 4.400 6th: 3.410 7th: 2.645	8th: 2.050 9th: 1.598 10th: 1.239 11th: 1.000 12th: 0.775
Reverse	RHigh: 9.900 RLow: 12.774	
PTO Opening	Rear	

PROPELLER SHAFT

Type	Single Main Shaft GW5E2200, Inter-axle Shaft P12
------	--

FRONT AXLE

Axle Version	FUSO F900T "I" Beam
Type	Reverse Elliot "I" Beam
Design Capacity (kg)	7,100
Max Operating Capacity (kg)	7,100 (Subject to suitable tyres and certification)

FRONT SUSPENSION

Type	Long Taper Leaf with Double Acting Shock Absorbers
Size (mm)	1,500 x 90 Leaves

REAR AXLE

Type	Full Floating Hypoid Type Tandem Drive with Inter-Axle Diff Lock
Axle Version	FUSO D12HT/12H
Design Capacity (kg)	21,600
Max Operating Capacity (kg)	21,600
Ratio	4.222:1

SPECIFICATIONS - FV2447 HI TOP TRACTOR

REAR SUSPENSION

Type	Air Suspension
Details	Trailing Arm with Air Dump control and Double Acting Shock Absorbers
Size Main Leaves (mm)	Air Bags (250mm) x 4

STEERING

Power Assisted	Tilt/Telescopic Adjustable Steering Wheel
----------------	---

BRAKES

Type	Full Air Taper Roller Drum Brakes with auto adjust, ABS plus ASR (Traction Control)
Size Front / Rear (mm)	410 x 150 / 410 x 200
Park Brake	Rear Wheel Spring Actuated
Engine Brake	4 Stage Powertard + Exhaust brake with Shift Down Function
Compressor	636cc with air dryer
Trailer Control Lever	Yes
Air tanks	Alloy

WHEELS AND TYRES

Wheel Type	10 x Alcoa Alloy
Wheel Size	22.5 x 8.25DC
Wheel Stud Pattern	ISO 10 x 335mm PCD
Tyre Size Front / Rear	275 / 70R22.5

CHASSIS

Type	Super Frame Reinforced Parallel Channel
Size (mm)	300 x 90 x 7.0
Width (mm)	840

OPTIONS

Options	Reverse camera and navigation system
---------	--------------------------------------

INSTRUMENTS

Gauges	Speedometer with Odometer Tachometer Air Pressure (2) Fuel Level Water Temperature AdBlue Level
Colour Information Display	Fuel Consumption Service Indicators Hour Meter and Tripmeter Oil Level Check

STANDARD FEATURES

Airbag	Driver's Air Bag and Seat Belt Pre-tensioner
Hill Start System	Yes
Speed Limiter 100km/hr	Activated by dealer
Cab Cooling and Heating	Climate Control
Accessory Power	24V Accessory Power Outlet/Cigar Lighter
Driving	Keyless Central Locking Cruise Control Electric Windows LH Transom Window Cup Holders Fluorescent Cabin Lamp and Interior Reading Lamps Engine Idle Speed Control
Audio	Multi Media 6.1" Touch screen audio with AM/FM/DAB radio, Bluetooth, USB Port and DVD player
Storage	Large Centre Storage Console Rear Bunk Storage Pocket Dash Storage Tray 2 DIN Overhead Console boxes
Chassis	Reverse Warning Buzzer

CAB FEATURES

Type	All Steel Forward Control Electric / Hydraulic Tilt Cab
Cab Structure	Meets ECE-R29 European Cab Strength (max front axle weight 6.5T); Door Side Impact Beams
Mounting	4 point Air Suspended Front and Rear
Doors	90deg Opening
Colour	Natural White (W31)
Windscreen	Laminated Tinted Rear Quarter Glass
Windscreen Wipers	2 Speed + Intermittent Cycle with Integrated Washer Nozzles
Rear Vision Mirrors	Remote Control / Heated with Convex Spotter (Both Sides)
Seating Capacity	2
Seat Belts	Lap Sash Belts
Seat (driver)	ISRI Air Suspension with Auto Levelling, Height, Tilt and Dampening Adjustment
Seats (passenger)	Bucket seat with Integral Headrest and Fabric Trim
Interior	Fully trimmed with rear bunk mattress Carpet on floor; Curtains
External	Roof Mounting Points (max. static load 50kg) Front End-Outline Marker Lamps Lift up front maintenance panel

SERVICE INTERVALS

Please contact your nearest Fuso dealer for details

WARRANTY

36 months or 250,000km (whichever occurs sooner)
Subject to terms and conditions in the Fuso Warranty Booklet

KERB WEIGHTS AND MAX AXLE LOADS (kg)

Model	Vehicle Ratings**		Max Axle Loadings**		Kerb Weights*		
	GVM	GCM	Front***	Rear	Front	Rear	Total
6x4 HD FV2447 12 Sp. AMT Air Susp. FV54SJR5VFAB	24,000	60,000	7,100	21,600	4,350	3,170	7,520

* Weights (est.) includes 10L fuel and spare wheel and are subject to 2.5% variation (+/-)

** Vehicle ratings and max axle loadings may be limited by local regulations.

*** Subject to suitable tyres and certification

SPECIFICATIONS - FV2447 HI TOP TRACTOR

PERFORMANCE

Turning Circle (kerb to kerb - metres)	12.8
Road Speed (km/h) at Max Engine Speed	118
Engine Speed (rpm) 90km/hr (top gear)	1695
Gradeability at Rated GCM (theoretical)*	26%
Notes	*This is theoretical performance only. Actual performance may vary under different conditions

DIMENSIONS (mm)

Wheelbase	3,860
Length Overall	6,690
Height Overall	3,610
Width Overall	2,490
Width Rear Axle	2,485
Width Front Track	2,075
Width Rear Track	1,865
Width Frame	840
Height Frame at Rear Axle	Air Suspension Inflated = 983

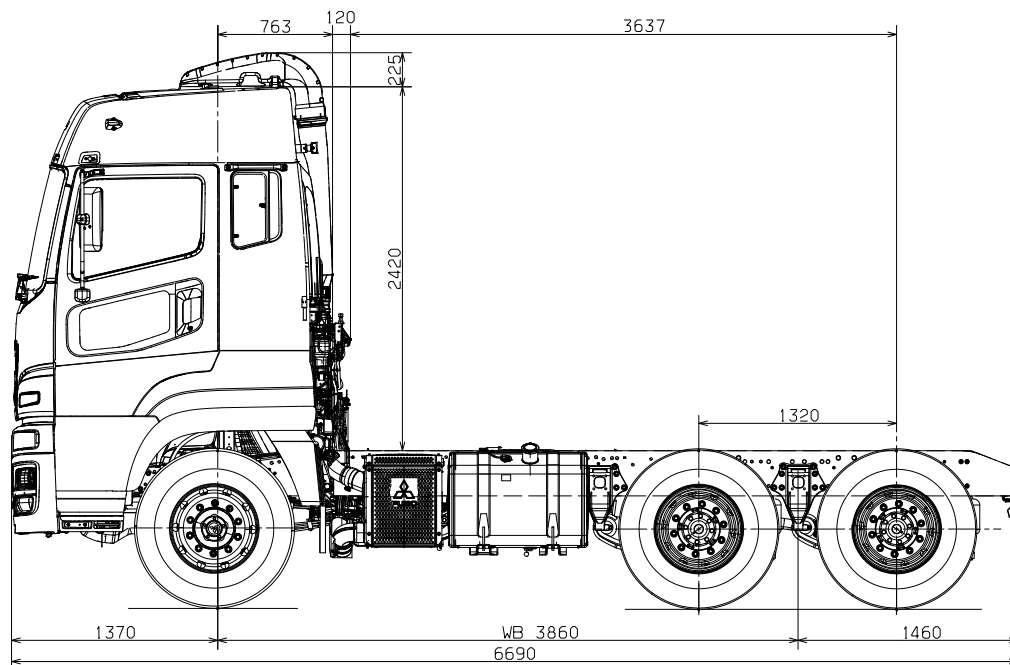

HD FV2447 HI TOP TRACTOR- 'J' WHEELBASE

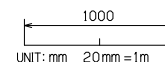

Scale = 1:50 (20mm = 1 metre). This scale is accurate when used on the original spec sheet, be aware that enlarging these illustrations can alter the scale and cause incorrect measurements. Fuso New Zealand and its authorised dealers always recommend customers seek professional advice from independent sources before commencing any engineering activities.

A policy of continual improvement means that specifications detailed in this brochure are subject to change without notice. Contact your authorised Fuso dealer to confirm current specifications. Fuso is a registered trademark of Mitsubishi Fuso Truck & Bus Corporation. Copyright © Fuso NZ (2017)