

CANTER EURO 4.0T



GVM	GCM	POWER	W/BASE	CODE
5995kg	9500kg	157ps (JIS Gross)	3400mm	FEB71ER3WFAC
5995kg	9500kg	157ps (JIS Gross)	3850mm	FEB71GR3WFAC
7500kg	11000kg	157ps (JIS Gross)	3400mm	FEB71ER3WFAC
7500kg	11000kg	157ps (JIS Gross)	3850mm	FEB71GR3WFAC

PERFORMANCE

Maximum Speed: 127 Km/h
 Gradeability at Rated GVM: 31%
 Turning Circle (kerb to kerb): E=12.2m, G=13.6m

COOLING

Fan: 460mm Diameter with 9 Blades
 Fan Drive: Viscous Coupling
 Radiator: Corrugated Fin with expansion tank

STEERING

Type: Integral Power Assisted Ball
 Steering Wheel: Urethane with Airbag
 Steering Column: Tilt/Telescopic Adj

ENGINE

Mitsubishi 4P10-7AT4 (Euro V)

Description: 4 Cylinder
 Configuration: Inline -DOHC 4 Valve
 Type: Variable Geometry Turbo Charged with Air to Air Intercooler
 Displacement: 2,998cc 95.8x104mm
 Power (DIN Nett): 110kw @ 2840 to 3500rpm
 Torque (DIN Nett): 370Nm @ 1350 to 2840 rpm
 Compression Ratio: 17.5:1
 Oil Cooler: Water Cooled

ELECTRICAL

Voltage: 12 volt
 Alternator Capacity: 110 amp
 Battery Capacity: 2 x 12V 90AH
 Headlamp: Halogen 55/60W
 Fog lamp: Front Bumper

BRAKES

Type: Hydraulic Dual Circuit with ABS/EBD. Dual Caliper Ventilated Disc Front and Rear Brake Override safety system
 Size: F 252 x 40mm, R 252 x 40mm
 Park Brake: Transmission Mounted
 Auxiliary: Exhaust Brake

CLUTCH

Description: Fully Automated Wet Dual Clutch

FRONT SUSPENSION

Type: Semi-Elliptic Leaf Springs with Shock Absorbers & Stabilizer
 Size: 1150x70x10 - 3 leaf, 11 - 2 leaf

4P10-7AT6

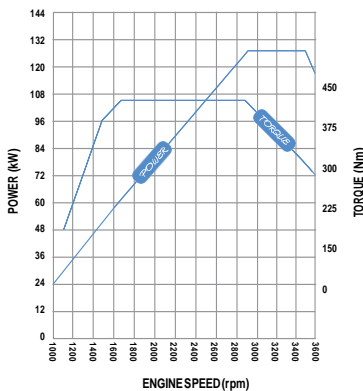

TRANSMISSION

Description: FUSO Duonic M038S6 AMT
 No. of Speeds: 6
 Ratios: - 1st: 5.397
 - 2nd: 3.788
 - 3rd: 2.310
 - 4th: 1.474
 - 5th: 1.000
 - 6th: 0.701
 - Rev: 5.397
 PTO Opening: LH side

REAR SUSPENSION

Type: Semi-Elliptic Leaf Springs with Shock Absorbers & Stabilizer
 Size: 1250 x 70 x 10 - 2 leaf
 12 - 1, 10 - 3
 Auxiliary: 880 x 70 x 15 - 3 leaf

PROPELLER SHAFT

Type: P3
 Universal Joint: Needle Roller

CHASSIS

Type: Reinforced Taper Channel
 Size: 192x60x6mm
 Width: 752mm
 Tensile Strength: 440 mpa

FUEL

Pump: Bosch Common Rail
 Governor: Electronic
 Filtration: Main Filter with Water Separator
 Fuel Capacity: 100 Litre/Lockable
 Air Cleaner: Dry Paper Element/Vertical Intake

FRONT AXLE

Type: Mitsubishi Reverse Elliot 'I' Beam
 Design Capacity: 3100kg
 Maximum Operating Capacity: 3100kg

WHEELS & TYRES

Wheel Type: Single piece tubeless rims
 Wheel Size: 17.5"
 Tyre Size: 215/75R17.5
 Spare & Tyre Carrier: YES

EMISSION SYSTEMS

Emission Standard: Euro V + Enhanced Environmentally Friendly Vehicle (EFV)

REAR AXLE

Description: Mitsubishi D035H
 Type: Full floating Hypoid
 Design Capacity: 6000kg
 Maximum Operating Capacity: 6000kg
 Ratio: 5.714

Diesel Particulate Filter (DPF) Exhaust with DPF Status on dash display



KERB WEIGHT (kg – estimated)

	E2	G2
Front:	1750	1775
Rear:	900	900
Total:	2650	2675

Includes coolant, oils and 20 litres fuel.

DIMENSIONS (mm)

	E2	G2
Wheel Base:	3400	3850
Overall Length:	5935	6685
Cab to Axle:	1821	2270
Rear Overhang:	1395	1695
Overall Height:	2225	2225
Overall Width:	1995	1995
Track Front:	1675	1675
Track Rear:	1560	1560

CAB FEATURES**All Steel Forward Control. ECE R29 Safety Cab**

Type:	Fixed Double Cab
Mounting:	Hydroelastic 4 point
Colour:	White W31
Interior:	Fully Trimmed
Windscreen:	Laminated and Tinted
Windscreen Wipers:	2 Speed-Intermittent with Integrated Washer Nozzles
Rear Vision Mirrors:	1 Internal 2 x External Convex-Heated
Seating Capacity:	7
Seat Belts:	Driver – Height adjustable 3 point ELR with tension reducer Front Passenger – ELR 3 point, Centre: 2 Point Rear Passenger – Outer position: ELR 3 point Centre: 2 point
Driver Seat:	Suspension base, Fabric trim with built in headrest, lumbar support and armrest
Passenger Seat:	Flat folding 2 passenger bench type with left-hand headrest and fabric trim
Rear Seats:	Bench type, 4 person, fabric Headrest right and left sides

INSTRUMENTS**Gauges:**

- Speedo with Odometer and Dual Trip Meter
- Tachometer
- Fuel Level

Warning Lights:

- High Beam
- Turn signal/Hazard warning
- Park Brake
- Exhaust Brake
- Engine Pre-Heat
- Alternator
- Low Oil Pressure
- SRS Airbag
- Brake Pad Wear
- Immobilizer
- Seat Belts
- DPF
- AMT Oil Temp
- AMT Fault

SWITCHES

- Fog Lamps
- Fluorescent Cab Lamp
- Heated Exterior Mirrors
- DPF Regeneration switch
- Transmission Economy Mode Switch
- Hazard Lights

**CAB EQUIPMENT**

- Driver's & front passenger airbag
- Electric Windows with one touch drivers
- Keyless Central Locking
- Door side impact beams
- Tinted side and rear glass
- Heater-Demister/Air-conditioning
- Interior sunvisors LH/RH
- AM/FM CD radio with 2 speakers
- Fluorescent Cabin Lamp
- Interior Front & Rear Dome Lamp with Delay Function
- Front Step lamps
- Cab Front Outline Marker Lights
- Cigar Lighter
- Electric Horn
- Reverse Warning Buzzer
- Tool Kit
- Overhead Parcel Shelves LH/RH
- Lower Dash Document Holder
- Engine access panel

MULTI FUNCTION DISPLAY

- Calendar/Time
- Meter and Gauge Illumination
- Service Reminders
- DPF Level indication
- Fuel Consumption Indication
- Diagnostic Trouble Code Indication
- Coolant Temperature Gauge
- Gear Position Indicator
- Odo and Dual trip meter

CANTER EURO 4.0t

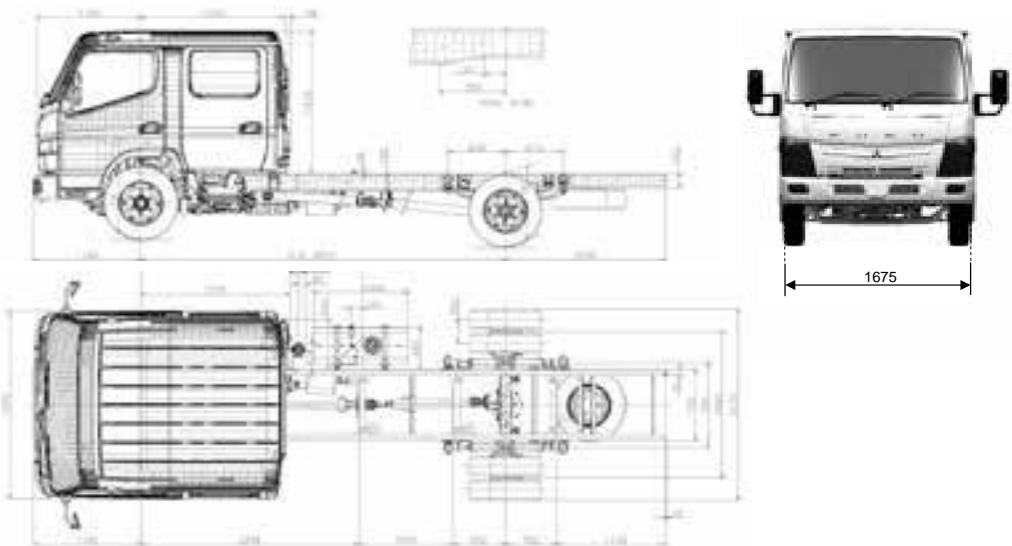

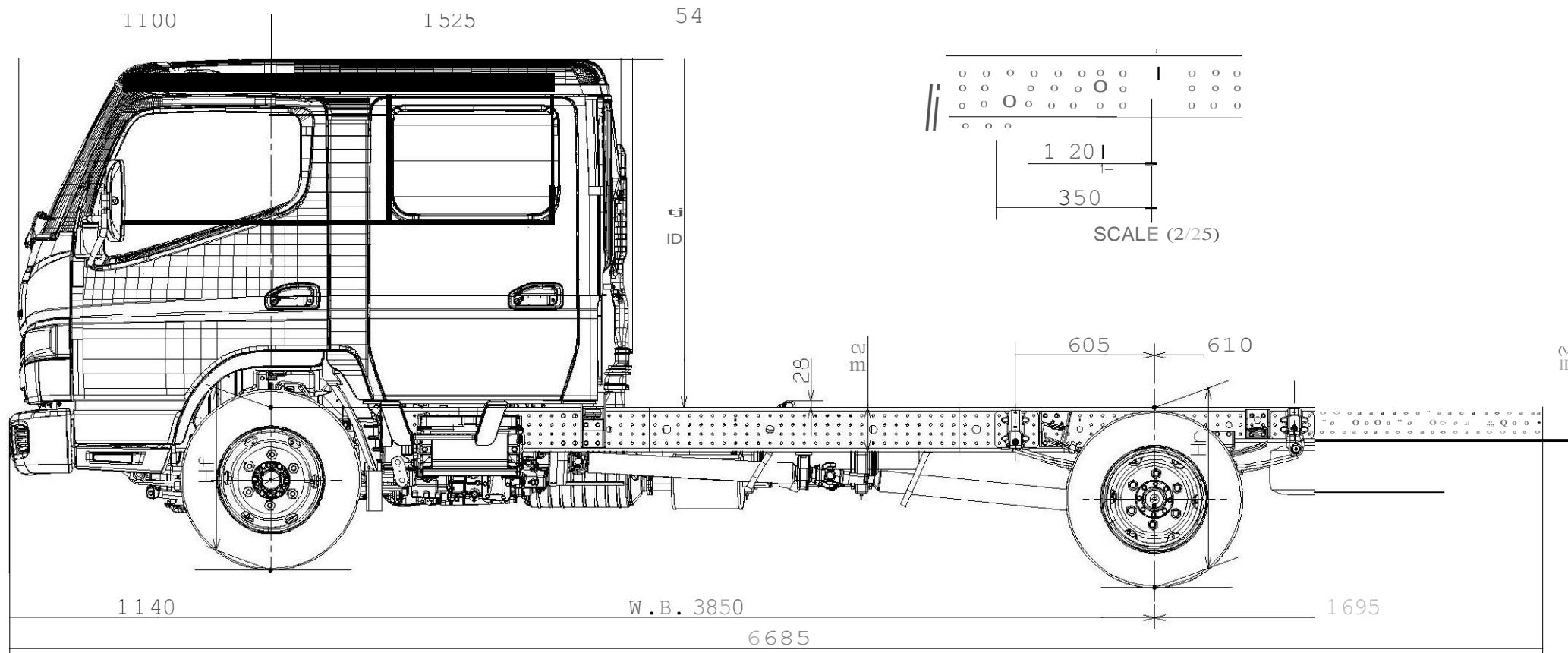
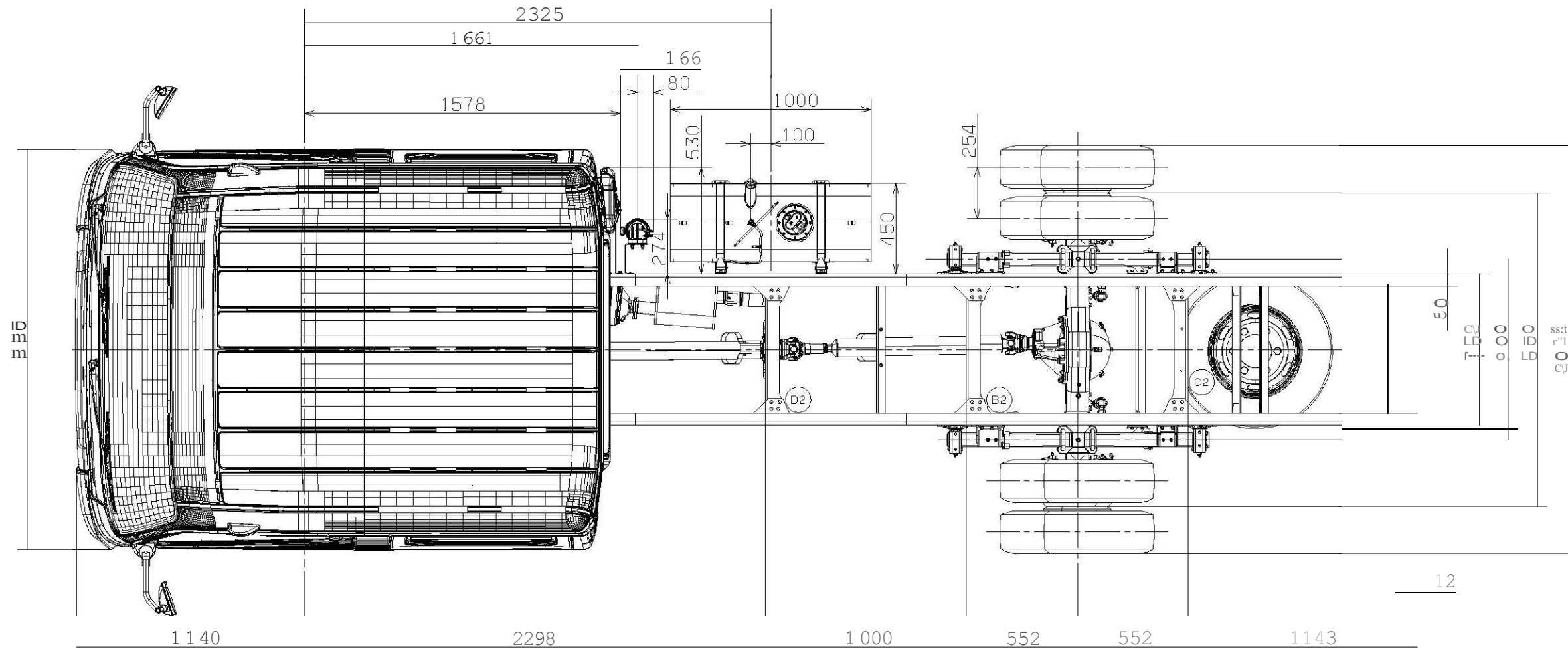

CHASSIS CAB
DRAWINGS

FEB71GR3WFAC
UNJT : mm
SCALE : 1/25