

# CANTER EURO 4.0T



GVM	GCM	POWER	W/BASE	CODE
5995kg	9500kg	157ps (JIS Gross)	3400mm	FEB71ER3WFAC
5995kg	9500kg	157ps (JIS Gross)	3850mm	FEB71GR3WFAC
7500kg	11000kg	157ps (JIS Gross)	3400mm	FEB71ER3WFAC
7500kg	11000kg	157ps (JIS Gross)	3850mm	FEB71GR3WFAC

## PERFORMANCE

Maximum Speed: 127 Km/h  
 Gradeability at Rated GVM: 31%  
 Turning Circle (kerb to kerb): E=12.2m, G=13.6m

## COOLING

Fan: 460mm Diameter with 9 Blades  
 Fan Drive: Viscous Coupling  
 Radiator: Corrugated Fin with expansion tank

## STEERING

Type: Integral Power Assisted Ball  
 Steering Wheel: Urethane with Airbag  
 Steering Column: Tilt/Telescopic Adj

## ENGINE

### Mitsubishi 4P10-7AT4 (Euro V)

Description: 4 Cylinder  
 Configuration: Inline -DOHC 4 Valve  
 Type: Variable Geometry Turbo Charged with Air to Air Intercooler  
 Displacement: 2,998cc 95.8x104mm  
 Power (DIN Nett): 110kw @ 2840 to 3500rpm  
 Torque (DIN Nett): 370Nm @ 1350 to 2840 rpm  
 Compression Ratio: 17.5:1  
 Oil Cooler: Water Cooled

## ELECTRICAL

Voltage: 12 volt  
 Alternator Capacity: 110 amp  
 Battery Capacity: 2 x 12V 90AH  
 Headlamp: Halogen 55/60W  
 Fog lamp: Front Bumper

## BRAKES

Type: Hydraulic Dual Circuit with ABS/EBD. Dual Caliper Ventilated Disc Front and Rear Brake Override safety system  
 Size: F 252 x 40mm, R 252 x 40mm  
 Park Brake: Transmission Mounted  
 Auxiliary: Exhaust Brake

## CLUTCH

Description: Fully Automated Wet Dual Clutch

## FRONT SUSPENSION

Type: Semi-Elliptic Leaf Springs with Shock Absorbers & Stabilizer  
 Size: 1150x70x10 - 3 leaf, 11 - 2 leaf

### 4P10-7AT6

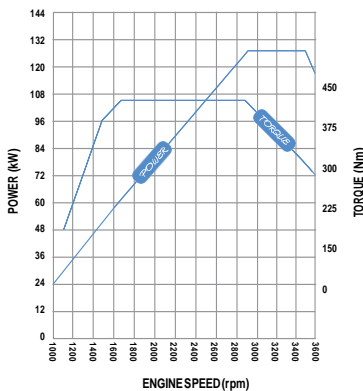

## TRANSMISSION

Description: FUSO Duonic M038S6 AMT  
 No. of Speeds: 6  
 Ratios: - 1st: 5.397  
 - 2nd: 3.788  
 - 3rd: 2.310  
 - 4th: 1.474  
 - 5th: 1.000  
 - 6th: 0.701  
 - Rev: 5.397  
 PTO Opening: LH side

## REAR SUSPENSION

Type: Semi-Elliptic Leaf Springs with Shock Absorbers & Stabilizer  
 Size: 1250 x 70 x 10 - 2 leaf  
 12 - 1, 10 - 3  
 Auxiliary: 880 x 70 x 15 - 3 leaf

## PROPELLER SHAFT

Type: P3  
 Universal Joint: Needle Roller

## CHASSIS

Type: Reinforced Taper Channel  
 Size: 192x60x6mm  
 Width: 752mm  
 Tensile Strength: 440 mpa

## FUEL

Pump: Bosch Common Rail  
 Governor: Electronic  
 Filtration: Main Filter with Water Separator  
 Fuel Capacity: 100 Litre/Lockable  
 Air Cleaner: Dry Paper Element/Vertical Intake

## FRONT AXLE

Type: Mitsubishi Reverse Elliot 'I' Beam  
 Design Capacity: 3100kg  
 Maximum Operating Capacity: 3100kg

## WHEELS & TYRES

Wheel Type: Single piece tubeless rims  
 Wheel Size: 17.5"  
 Tyre Size: 215/75R17.5  
 Spare & Tyre Carrier: YES

## EMISSION SYSTEMS

Emission Standard: Euro V + Enhanced Environmentally Friendly Vehicle (EFV)

## REAR AXLE

Description: Mitsubishi D035H  
 Type: Full floating Hypoid  
 Design Capacity: 6000kg  
 Maximum Operating Capacity: 6000kg  
 Ratio: 5.714

Diesel Particulate Filter (DPF) Exhaust with DPF Status on dash display



**KERB WEIGHT** (kg – estimated)

	<b>E2</b>	<b>G2</b>
Front:	1750	1775
Rear:	900	900
Total:	2650	2675

Includes coolant, oils and 20 litres fuel.

**DIMENSIONS** (mm)

	<b>E2</b>	<b>G2</b>
Wheel Base:	3400	3850
Overall Length:	5935	6685
Cab to Axle:	1821	2270
Rear Overhang:	1395	1695
Overall Height:	2225	2225
Overall Width:	1995	1995
Track Front:	1675	1675
Track Rear:	1560	1560

**CAB FEATURES****All Steel Forward Control. ECE R29 Safety Cab**

Type:	Fixed Double Cab
Mounting:	Hydroelastic 4 point
Colour:	White W31
Interior:	Fully Trimmed
Windscreen:	Laminated and Tinted
Windscreen Wipers:	2 Speed-Intermittent with Integrated Washer Nozzles
Rear Vision Mirrors:	1 Internal 2 x External Convex-Heated
Seating Capacity:	7
Seat Belts:	Driver – Height adjustable 3 point ELR with tension reducer Front Passenger – ELR 3 point, Centre: 2 Point Rear Passenger – Outer position: ELR 3 point Centre: 2 point
Driver Seat:	Suspension base, Fabric trim with built in headrest, lumbar support and armrest
Passenger Seat:	Flat folding 2 passenger bench type with left-hand headrest and fabric trim
Rear Seats:	Bench type, 4 person, fabric Headrest right and left sides

**INSTRUMENTS****Gauges:**

- Speedo with Odometer and Dual Trip Meter
- Tachometer
- Fuel Level

**Warning Lights:**

- High Beam
- Turn signal/Hazard warning
- Park Brake
- Exhaust Brake
- Engine Pre-Heat
- Alternator
- Low Oil Pressure
- SRS Airbag
- Brake Pad Wear
- Immobilizer
- Seat Belts
- DPF
- AMT Oil Temp
- AMT Fault

**SWITCHES**

- Fog Lamps
- Fluorescent Cab Lamp
- Heated Exterior Mirrors
- DPF Regeneration switch
- Transmission Economy Mode Switch
- Hazard Lights

**CAB EQUIPMENT**

- Driver's & front passenger airbag
- Electric Windows with one touch drivers
- Keyless Central Locking
- Door side impact beams
- Tinted side and rear glass
- Heater-Demister/Air-conditioning
- Interior sunvisors LH/RH
- AM/FM CD radio with 2 speakers
- Fluorescent Cabin Lamp
- Interior Front & Rear Dome Lamp with Delay Function
- Front Step lamps
- Cab Front Outline Marker Lights
- Cigar Lighter
- Electric Horn
- Reverse Warning Buzzer
- Tool Kit
- Overhead Parcel Shelves LH/RH
- Lower Dash Document Holder
- Engine access panel

**MULTI FUNCTION DISPLAY**

- Calendar/Time
- Meter and Gauge Illumination
- Service Reminders
- DPF Level indication
- Fuel Consumption Indication
- Diagnostic Trouble Code Indication
- Coolant Temperature Gauge
- Gear Position Indicator
- Odo and Dual trip meter

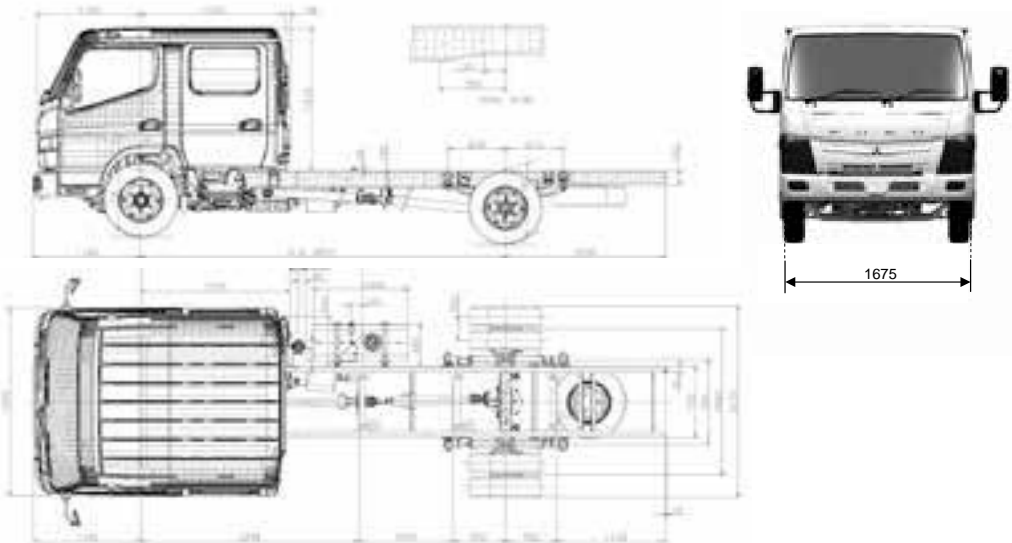
**CANTER EURO 4.0t**

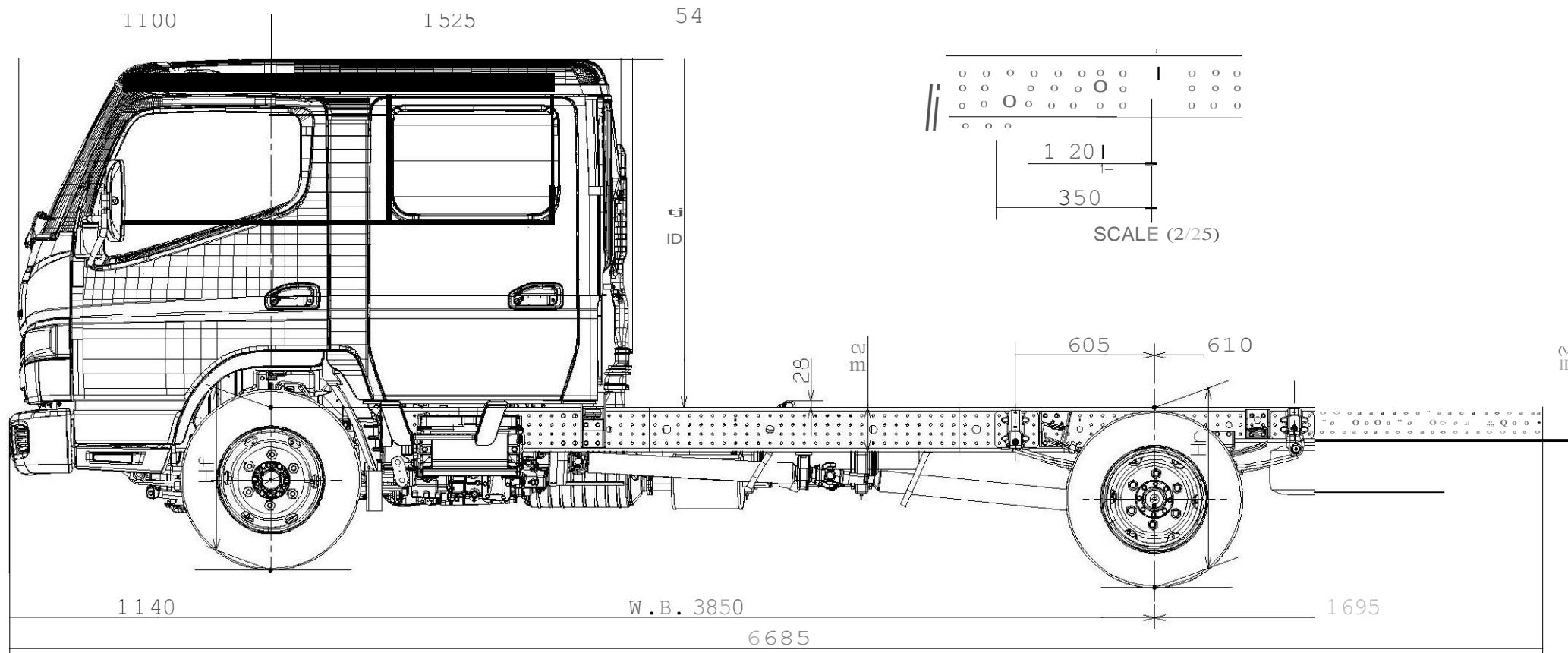
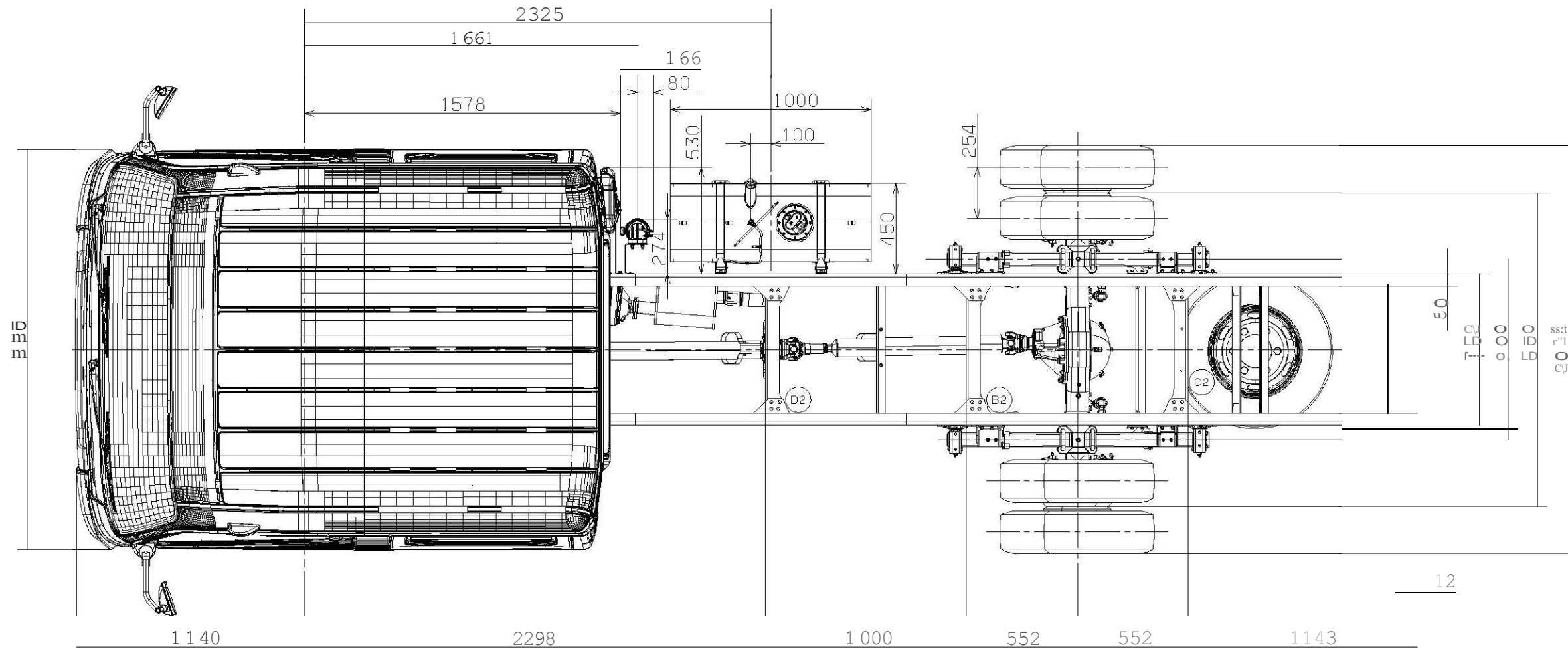

CHASSIS CAB  
DRAWINGS

FEB71GR3WFAC  
UNJT : mm  
SCALE : 1/25