

# FIGHTER 280



GVM	GCM	POWER	W/BASE	CODE
13,500kg	20,000kg	280ps	5,210	FK65FLZ2RFAC
12,000kg	20,000kg	280ps	5,210	FK65FLZ2RFAC

## PERFORMANCE

Electronic Speed Limited:	100 km/h
Gradeability at Rated GVM:	43.0%
Gradeability at Rated GCM:	27%
Turning Circle (kerb to kerb):	18.2m

## ENGINE

### Mitsubishi FUSO 6M60-9AT2 Diesel (Euro V)

Configuration:	6 cyl. in-line OHC, 4-valve
Type:	Turbocharged with air to air intercooler PCV & common rail fuel system SCR after-treatment system (BlueTec)
Displacement:	7,545cc
Bore:	118mm
Stroke:	115mm
Power (JIS Gross):	207kW (281ps) @ 2,500rpm
Torque (JIS Gross):	802Nm (592lb/ft) @ 1,100-2,400rpm
Maximum Engine Speed:	2,900 rpm
Compression Ratio:	16:0:1
Oil Cooler:	Plate type, water cooled
Air Cleaner:	Dual element cyclonic with vertical intake & air restriction indicator

### 6M60-9AT2 DIESEL ENGINE MODEL

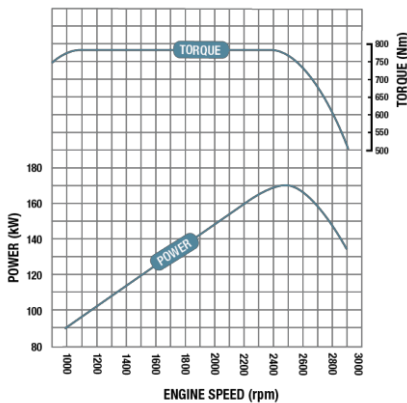

## FUEL

Injection System:	DENSO common rail system
Governor:	Electronic
Fuel Tank:	200 Litres Rectangular with Lockable Cap
Fuel Cooler:	Fitted
AdBlue Exhaust Fluid Capacity:	25 litres

## COOLING

Fan:	540mm dia. 10 blades
Fan Drive:	Thermo modulated
Radiator:	Corrugated fin with expansion tank

## ELECTRICAL

Voltage:	24V negative earth
Alternator Capacity:	24V-80 amp
Starter Capacity:	24V-5.0kW
Battery Capacity:	Heavy duty 2 x 12V, 100Ah/20hr
Headlamp – Type:	Halogen
– Capacity:	Low beam 2 x 70W High beam 2 x 75W

## CLUTCH

<b>Model:</b>	<b>C7M38</b>
Disc Diameter:	380mm
Type:	Single dry plate
Operation:	Air assisted hydraulic
Facing Area:	Ceramic – 754cm <sup>2</sup>

## TRANSMISSION

<b>Model:</b>	<b>M070S6-0D</b>
No. of Speeds:	6 with air assisted gearshift
Synchromesh:	2nd-6th
1:	6.807
2:	4.172
3:	2.396
4:	1.504
5:	1.00
6:	0.774
Reverse:	6.807
PTO Opening:	LH Side

## PROPELLER SHAFT

Type:	P10
Universal Joint:	Needle roller

## FRONT AXLE

<b>Model:</b>	<b>F500T</b>
Type:	Reverse Elliot 'T' beam
Design Capacity:	5,000kg
Maximum Operating Capacity:	5,000kg

## REAR AXLE

<b>Model:</b>	<b>R052T</b>
Type:	Full floating hypoid
Design Capacity:	9,500kg
Maximum Operating Capacity:	9,200kg
Ratio:	4.875:1

## STEERING

Type:	Integral power assisted – ball & nut
Steering Wheel:	Airbag
Steering Column:	Tilt/telescopic adjustable with lock

## BRAKES

Type:	Full air, dual circuit, Mitsubishi taper roller with automatic brake adjustment, EZGO hill start assist & ABS
Size:	Front: 370 x 150mm Rear: 370 x 150mm
Park Brake:	Rear wheel spring actuated
Auxiliary:	Exhaust brake
Compressor:	Water cooled, 340cc single cylinder with air dryer

## FRONT SUSPENSION

Type:	Parabolic Leaf
Size:	1,300 x 70 x 16mm – 2 leaves x 18mm – 2 leaves
Capacity at Ground:	2,700kg each
Shock Absorbers:	Double Acting

## REAR SUSPENSION

Type:	Trailing arm with air dump control
Air Spring:	2 x 270mm diameter
Trailing arm: (683+424) x 80 x 35mm – 2 leaves	
Capacity at Ground:	9,500kg total
Shock Absorbers:	Double acting

## CHASSIS

Type:	Parallel Channel with reinforcement
Size:	230 x 80 x 8.0mm
Width:	844mm
	540Mpa



4X2

## WHEELS & TYRES

Wheel:	Type:	6 x Single piece disc
	Size:	19.5 x 6.75-147
	Stud pattern:	8 x 285mm PCD
Tyre:	Size:	265/70R19.5 140/138M

## KERB WEIGHT (kg – estimated)

Front:	2,460kg
Rear:	1,535kg
Total:	3,995kg

*Includes coolant, oils, tools and 20 litres fuel.*

## CAB FEATURES

### All steel forward control

Type:	Manual tilt 44 deg
Mounting:	Hydroelastic susp 4 point
Colour:	Natural White
Interior:	Fully trimmed with vinyl floor mat
Windscreen:	Laminated tinted
Windscreen Wipers:	2 Speed + Intermittent Cycle with Integrated Washer Nozzles
Door:	90 degree opening angle
Steering Column:	Telescopic & Tilt
Rear Vision Mirrors:	Remote / heated with Convex Spotter (both sides)
Seating Capacity:	3
Seat Belts:	2 ELR lap sash, 1 lap with pre-tensioners
Seats:	Driver: ISRI air suspension with auto levelling, height, tilt and dampening adjustment Integral headrest & fabric trim
Centre:	Low back with fabric trim & forward folding
LH:	Fixed base, reclining, integral headrest & fabric trim

## STANDARD FEATURES

### Safety

- ABS
- Driver's Air Bag
- Seat Belt Pre-tensioners
- LH Transom Window
- Reverse Warning Buzzer
- Heated and remote controlled exterior mirrors
- EZGO Hill Start Assist

### Driving

- Keyless Central Locking
- Electric Windows
- Cruise Control
- 24V Accessory Power Outlet/Cigar Lighter
- Air Conditioner/Heater/Demister
- Radio/CD Player/AUX/Bluetooth/Audio Streaming
- Cup Holders (4)
- Rear Quarter Glass
- Fluorescent Cabin Lamp and Interior Reading Lamps
- Engine Idle Speed Control

### Storage

- Centre Seat Storage Console
- LH Seat Storage Tray
- Rear Bunk Storage Pocket
- Dash Storage Tray 2 DIN Glove Compartment
- 1 Single & 1 Double DIN Slot for Accessories
- Overhead Storage Pocket with Lid
- RH Door Storage Pocket

### Cab External

- Roof Mounting Points (max. static load 70kg)
- Front End-Outline Marker Lamps

### Chassis

- Tool Kit & Chassis Mounted Tool Box

## INSTRUMENTS

### Gauges:

- Speedo with Odometer
- Tachometer
- Air pressure (2)
- Fuel level & urea level
- Water temperature

### Colour Information Display:

- Fuel consumption
- Service indicators
- Hour meter and tripmeter

### Warning Lamps:

- Glow plug indicator
- ABS
- Turn signal
- High beam
- Exhaust brake
- Oil level
- AdBlue low
- Fuel low
- Park brake
- Alternator
- Oil filter blockage
- Engine control/cruise control (ECU)
- Air filter restriction
- Door opening
- Cab tilt lock

### Warning Lamp/Buzzer:

- Air pressure
- Oil pressure
- Engine overheat/low coolant level

10.5 Chassis cab drawings

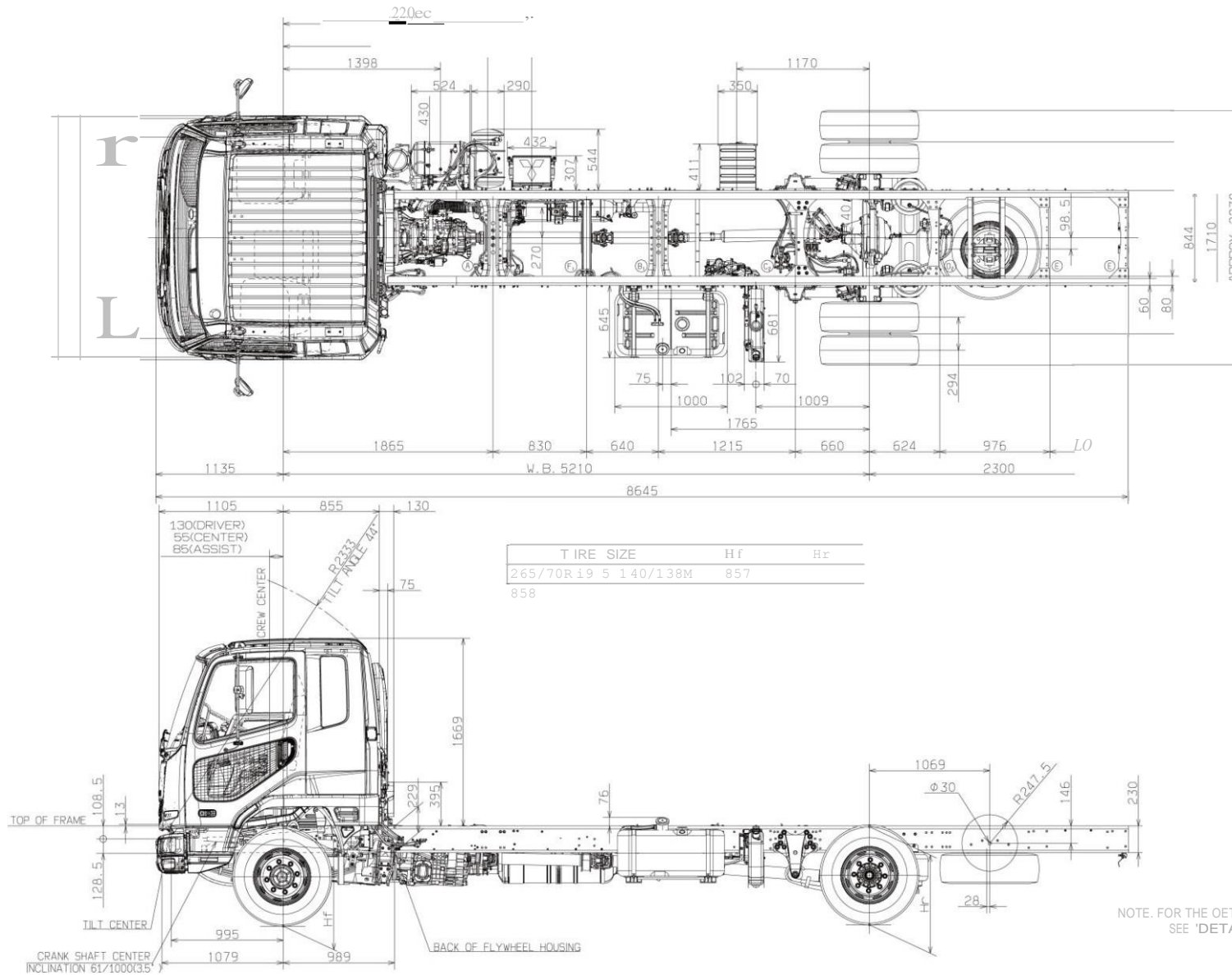

NOTE. FOR THE DETAILS OF CROSSMEMBERS, SEE 'DETAILS OF CROSSMEMBERS'

UNIT : mm  
SCALE : 1/40