

FIGHTER 280



GVM	GCM	POWER	W/BASE	CODE
16,000kg	32,000kg	280ps	5,550mm	FM67FM2RFAK
12,000kg	32,000kg	280ps	5,550mm	FM67FM2RFAK

PERFORMANCE

Electronically Speed Limited:	100 km/h
Gradeability at Rated GVM:	53.5%
Gradeability at Rated GCM:	23.5%
Turning Circle (kerb to kerb):	18.4m

ENGINE

Mitsubishi FUSO 6M60-9AT2 Diesel (Euro V)	
Configuration:	6 cyl. in-line OHC, 4-valve
Type:	Turbocharged with air to air intercooler PCV & common rail fuel system SCR after-treatment system (BlueTec)
Displacement:	7,545cc
Bore:	118mm
Stroke:	115mm
Power (JIS Gross):	207kW (281ps) @ 2,500rpm
Torque (JIS Gross):	802Nm (592lb/ft) @ 1,100-2,400rpm
Maximum Engine Speed:	2,900 rpm
Compression Ratio:	16:0:1
Oil Cooler:	Plate type, water cooled
Air Cleaner:	Dual element cyclonic with vertical intake & air restriction indicator

6M60-9AT2 DIESEL ENGINE MODEL

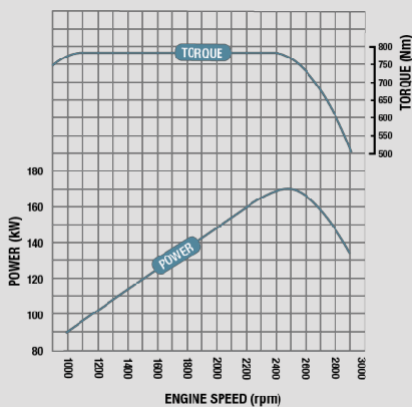

FUEL

Injection System:	DENSO common rail system
Governor:	Electronic
Fuel Tank:	300 Litres Rectangular with Lockable Cap
Fuel Cooler:	Fitted
AdBlue Exhaust Fluid Capacity:	40 litres

COOLING

Fan:	540mm dia. 10 blades
Fan Drive:	Thermo modulated
Radiator:	Corrugated fin with expansion tank

ELECTRICAL

Voltage:	24V negative earth
Alternator Capacity:	24V-80 amp
Starter Capacity:	24V-5.0kW
Battery Capacity:	Heavy duty 2x12V, 100Ah/20hr
Headlamp – Type:	Halogen
– Capacity:	Low beam 2 x 70W High beam 2 x 75W

CLUTCH

Model:	C7M38
Disc Diameter:	380mm
Type:	Single dry plate
Operation:	Air assisted hydraulic
Facing Area:	Cerametallic – 754cm ²

TRANSMISSION

Model:	Eaton ES-11109
No. of Speeds:	9 forward, 1 reverse
Synchromesh:	1L~4H Low High
Ratios:	- Low: 12.64 - 1st: 8.81 2.48 - 2nd: 6.55 1.85 - 3rd: 4.77 1.34 - 4th: 3.55 1.00 - Reverse: 13.21
PTO Opening:	LH Side

PROPELLER SHAFT

Type:	P12
Universal Joint:	Needle roller

FRONT AXLE

Model:	F650T
Type:	Reverse Elliot 'I' beam
Design Capacity:	6,300kg
Maximum Operating Capacity:	6,300kg

REAR AXLE

Model:	R080T/D10H
Type:	Full floating hypoid
Design Capacity:	10,800kg
Maximum Operating Capacity:	10,000kg
Ratio:	4.222:1

STEERING

Type:	Integral power assisted – ball & nut
Steering Wheel:	Airbag
Steering Column:	Tilt/telescopic adjustable with lock

BRAKES

Type:	Full air, dual circuit, Mitsubishi taper roller with automatic brake adjustment, EZGO hill start assist, ABS & ASR
Size:	Front: 410 x 150mm Rear: 410 x 200mm
Park Brake:	Rear wheel spring actuated
Auxiliary:	Exhaust brake
Compressor:	Water cooled, 340cc single cylinder with air dryer

FRONT SUSPENSION

Type:	Parabolic leaf
Size:	1,400 x 80 x 20mm – 1 leaf x 22mm – 2 leaves
Capacity at Ground:	3,665kg each
Shock Absorbers:	Double acting

REAR SUSPENSION

Type:	Trailing arm with air dump control
Air Spring:	2 x 250mm diameter
Auxiliary:	(643+390) x 80 x 35mm – 2 leaves
Capacity at Ground:	10,200kg each
Shock Absorbers:	Double acting

CHASSIS

Type:	Parallel channel
Size:	280 x 90 x 8.0mm
Width:	841mm
Tensile Strength:	540Mpa



WHEELS & TYRES

Wheel:	Type:	6 x Single piece disc
	Size:	22.5 x 8.25DC-165-13t
	Stud pattern:	10 x 335mm PCD
Tyre:	Size:	275/70R22.5 148/145K

KERB WEIGHT (kg – estimated)

Front:	2985kg
Rear:	1,940kg
Total:	4,925kg

Includes coolant, oils, tools and 20 litres fuel.

CAB FEATURES

All steel forward control

Type:	Manual tilt 44 deg
Mounting:	Hydroelastic susp 4 point
Colour:	Natural White
Interior:	Fully trimmed with vinyl floor mat
Windscreen:	Laminated tinted
Windscreen Wipers:	2 Speed + Intermittent Cycle with Integrated Washer Nozzles
Door:	90 degree opening angle
Steering Column:	Telescopic & Tilt
Rear Vision Mirrors:	Remote / heated with Convex Spotter (both sides)
Seating Capacity:	3
Seat Belts:	2 ELR lap sash, 1 lap with pre-tensioners
Seats:	Driver: ISRI air suspension with auto levelling, height, tilt and dampening adjustment Integral headrest & fabric trim
Centre:	Low back with fabric trim & forward folding
LH:	Fixed base, reclining, integral headrest & fabric trim

STANDARD FEATURES

Safety

- ABS
- Driver's Air Bag
- Seat Belt Pre-tensioners
- LH Transom Window
- Reverse Warning Buzzer
- Heated and remote controlled exterior mirrors
- EZGO Hill Start Assist

Driving

- Keyless Central Locking
- Electric Windows
- Cruise Control
- 24V Accessory Power Outlet/Cigar Lighter
- Air Conditioner/Heater/Demister
- Radio/CD Player/AUX/Bluetooth/Audio Streaming
- Cup Holders (4)
- Rear Quarter Glass
- Fluorescent Cabin Lamp and Interior Reading Lamps
- Engine Idle Speed Control

Storage

- Centre Seat Storage Console
- LH Seat Storage Tray
- Rear Bunk Storage Pocket
- Dash Storage Tray 2 DIN Glove Compartment
- 1 Single & 1 Double DIN Slot for Accessories
- Overhead Storage Pocket with Lid
- RH Door Storage Pocket

Cab External

- Roof Mounting Points (max. static load 70kg)
- Front End-Outline Marker Lamps

Chassis

- Tool Kit & Chassis Mounted Tool Box

INSTRUMENTS

Gauges:

- Speedo with Odometer
- Tachometer
- Air pressure (2)
- Fuel level & urea level
- Water temperature

Colour Information Display:

- Fuel consumption
- Service indicators
- Hour meter and tripmeter

Warning Lamps:

- Glow plug indicator
- ABS
- Turn signal
- High beam
- Exhaust brake
- Oil level
- AdBlue low
- Fuel low
- Park brake
- Alternator
- Oil filter blockage
- Engine control/cruise control (ECU)
- Air filter restriction
- Door opening
- Cab tilt lock

Warning Lamp/Buzzer:

- Air pressure
- Oil pressure
- Engine overheat/low coolant level

10.5 Chassis cab drawings

FM28 1M1 / FM281M 1D

fM67 fM2RfAK

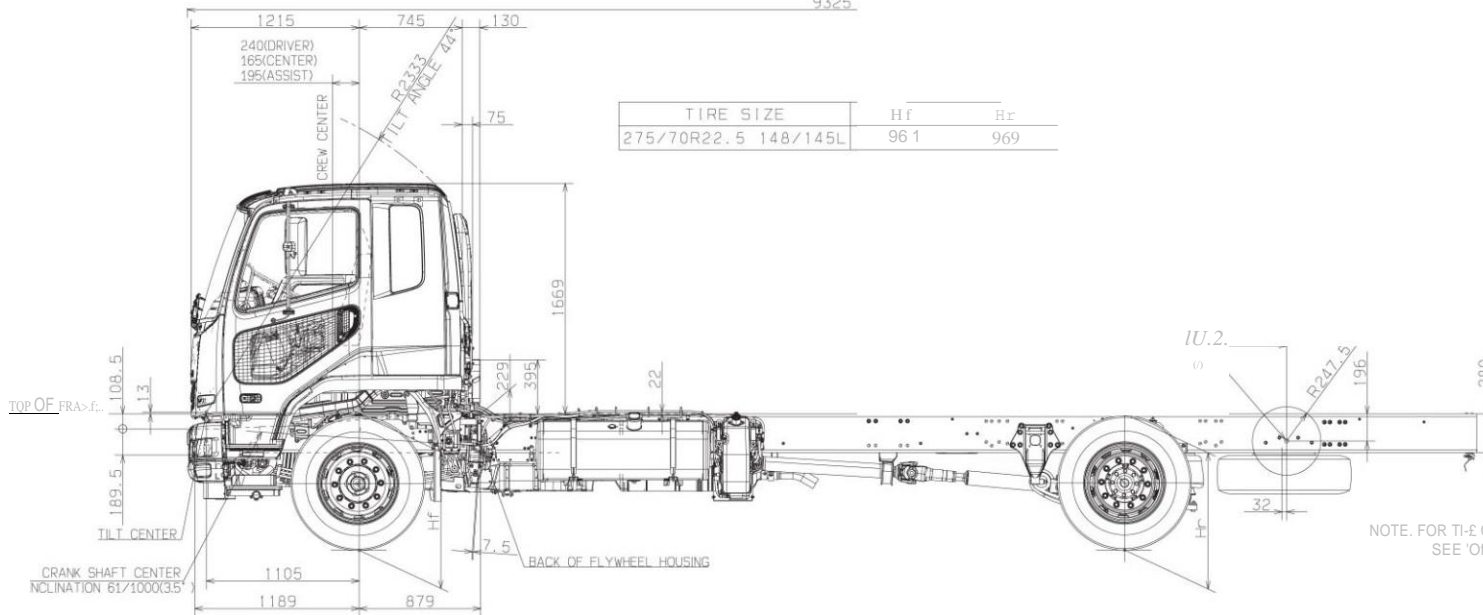
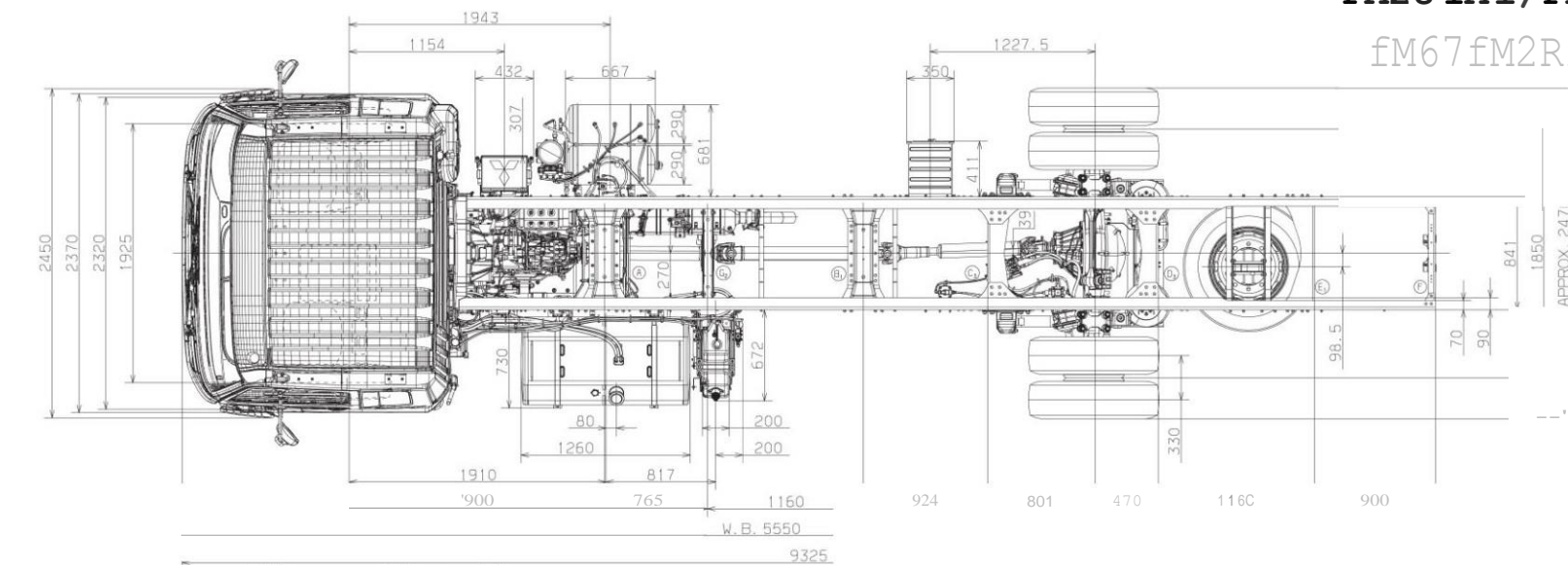

TIRE SIZE	Hf	Hr
275/70R22.5 148/145L	961	969

NOTE: FOR TIRE DETAILS OF CROSSMEMBERS. SEE 'DETAILS OF CROSSMEMBERS'

UNIT mm
SCALE 1/40