

FUSO HEAVY



CONFIGURATION	GVM	GCW	KERB WEIGHT	W/BASE	CODE
8X4	30.8T	55.0T	8920KG	5870MM	FS52SS5VFAA

PERFORMANCE

Maximum Speed:	118 km/hr
100km/hr speed limiter available	
Gradeability at Rated GCM:	29.5%
Turning Radius (kerb to kerb):	10.8 m

ENGINE

Mitsubishi Fuso OM457-T5 12L (Euro V)

Configuration:	Inline - 6 Cylinder
Type:	OHV, 4 Valve, Waste Gate Turbo with Intercooler
Displacement:	11967cc
Bore x Stroke:	128mm x 155mm
Power (DIN nett):	335 kw @ 1900 rpm (JIS Gross: 470 ps)*
Torque (DIN nett):	2200 Nm @ 1100 rpm (JIS Gross: 1644 lb/ft)*
Maximum Engine Speed:	2200 rpm
Compression Ratio:	18.5:1

*Calculated

OM457 ENGINE PERFORMANCE

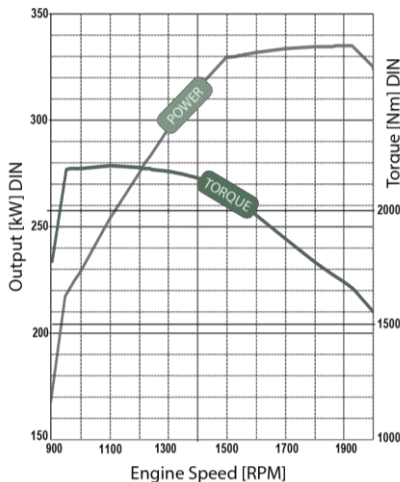

FUEL

Pump:	Bosch Unit Injectors
Governor:	Electronic
Filtration:	Main filter with waterseparator
Fuel Capacity:	400L Steel tank with lockable cap
Air Cleaner:	RHS snorkel with single element and electronic dust indicator
Cold Start Preheat:	Standard

EMISSION SYSTEM

Emission Standard:	Euro V
Box muffler LHS. Exhaust with BLUETEC® SCR After Treatment System 40L ADBLUE tank with on dash gauge	

COOLING

Fan:	750mm diameter with 8 Blades
Fan Drive:	Viscous Clutch
Radiator:	Aluminium

ELECTRICAL

Voltage:	24 volt neg earth
Alternator Capacity:	24v-80 amp
Heavy Duty Batteries:	2 x 12v, 150Ah/20hr

CLUTCH

Description:	C12W43P
Type:	Single dry plate 430 Woven facing material
Operation:	Fully Automated with Hill Start Assist

TRANSMISSION

Model: FUSO INOMAT II G230-12 AMT (2 Pedal Type)

No. of Speeds:	12
Ratios:	- 1st: 11.672
	- 2nd: 9.101
	- 3rd: 7.055
	- 4th: 5.501
	- 5th: 4.400
	- 6th: 3.430
	- 7th: 2.652
	- 8th: 2.068
	- 9th: 1.603
	- 10th: 1.250
	- 11th: 1.000
	- 12th: 0.779

Reverse:	High: 9.101:1	Low: 11.672:1
Control:	INOMAT 2 Automated shift with auto and manual shift modes and Hill Start Assist	
Additional Modes:	Start gear select, Slow Manoeuvre, Economy, Reverse high/low	
Oil Cooler:	T/M oil cooler (air cooling type)	
PTO Opening:	LHS and Rear mounting	

PROPELLER SHAFT

Type:	Main: GW5E220 with guard
	Interaxle: P12

FRONT AXLE

Type:	F900T
Maximum Operating Capacity:	14,200kg (Subject to suitable tyres & certification)

REAR AXLE

Description:	D10HT/D10H with Interaxle diff lock
Type:	Single Reduction Hypoid
Design Capacity:	21600kg
Maximum Operating Capacity:	21600kg
Ratio:	4.625

STEERING

Type:	Integral Power Assisted ball & nut
Steering Wheel:	Urethane with air bag
Steering Column:	Tilt & Teleopic adjust

BRAKES

Type:	Full air taper roller drum brakes with auto adjust ABS & ASR Traction control
Size:	F 410 x 150mm R 410 x 200mm
Park Brake:	Spring on both rear axles
Engine Brake:	4 stage Powertard with Exhaust Brake and Shift Down
Retardation Power:	320ps @ 2300 rpm
Compressor:	636cc with air dryer
Air Tanks:	Alloy

FRONT SUSPENSION

Type:	Long Taper Leaf
Size:	1500 x 90 x 23mm - 3
Capacity at Ground:	7280kg per axle
Shock Absorbers:	Double acting
Roll Bar:	Front axle

REAR SUSPENSION

Type:	Long Taper Leaf
Size:	1320 x 90 x 23mm - 3
Capacity at Ground:	22,500kg

CHASSIS

Type:	Super Frame parallel channel with tapered rear overhang
Size:	300 x 90 x 7mm
Width:	840mm
Tensile Strength:	540MPa

WHEELS & TYRES

Wheel Type:	Steel
Wheel Size:	8.25 x 22.5 - 165-23T
Wheel Stud Pattern:	10 Stud ISO
Tyre Size: Front	295/85R 22.5 & Rear: 11R22.5
Spare Tyre:	No

KERB WEIGHT (KG - ESTIMATED)

Front:	5765
Rear:	3155
Total:	8920

Includes coolant, oils and 20 litres fuel

DIMENSIONS (MM)

Wheel Base:	5870
Overall Length:	10140
Cab to Axle:	5170
Rear Overhang:	2867
Overall Height:	3330
Overall Width:	2490

OPTIONAL EQUIPMENT

- 4.222 + 275/70R22.5 LP Spec
- Reverse camera and navigation system

MULTI FUNCTION DISPLAY

- Calendar/Time
- Service Reminders
- Snow Mode - Low speed manoeuvring
- Fuel Consumption Indication
- Diagnostic Trouble Code Indication
- Gear Position Indicator
- Odo and Dual trip meter
- Engine Oil level check
- Warning/indicator display
- AdBlue level indicator
- Hour Meter
- Maintenance Indicator

CAB FEATURES

Construction:	All Steel Forward Control
Type:	Electric/Hydraulic 50 deg cab tilt
Mounting:	4 Point air suspension Colour: Natural White (W31)

Safety features:	European Safety Standard ECE-R29 90 degree opening doors with side intrusion bars
Lighting:	Halogen headlamps with Fog lights in bumper
Interior:	Fully trimmed with rear mattress
Windscreen:	Laminated & tinted
Windscreen Wipers:	3 windscreen wipers with built in nozzles 2 Speed & intermittent
Rear Vision Mirrors:	Remote control & heated flat main mirror with heated convex spotter
Seating Capacity:	2
Seats: Driver:	ISRI air suspension with auto levelling, height, tilt and dampening adjustment Integral headrest & fabric trim
Passenger:	Fixed base, 18 stage reclining, headrest & fabric trim
Seat belts:	Pretensioners, ELR attached 3 points type

INSTRUMENTS

Gauges:

- Speedo with Odometer and Dual Trip Meter
- Tachometer
- Fuel Level
- Dual air pressure gauge
- Water temperature meter

Warning Lamps:

- Park Brake
- Exhaust Brake/PowerTard
- Alternator
- Low Oil Pressure/Oil Filter Blockage
- SRS Air Bag
- Immobilizer
- Snow Mode - Low speed manoeuvring
- AMT oil Temp
- Engine check light
- Interaxle diff lock
- Brake air pressure
- Cold start indicator
- Door Open
- Low coolant level
- Cab tilt indicator
- Air filter restriction
- Cruise Control

CAB EQUIPMENT

Exterior:

- Halogen Headlamps
- Halogen fog lamps in bumper
- Roof mounted white marker lights x2
- Lift-up front maintenance panel
- Transom window on LH door
- Side intrusion bars & Front Underrun Protection
- 1 piece door pressing with 90 deg opening
- Front air dam
- Roof spoiler mounting points (max weight 50kg)

Interior:

- Fully trimmed
- Driver's air bag and seat belt pretensioners
- Large centre floor console with glove box
- Cup holder for driver
- Large overhead console boxes
- Tray under passenger seat
- Sun visors x 2
- Interior rear view mirror
- Opening rear quarter windows
- Grab handle on 'A' pillar
- Auto air conditioning with heater/demister
- Central locking and Keyless Entry System
- Power windows and Drivers auto up/down
- 6" Touch screen audio with Bluetooth, USB and DVD player with 2nd screen output.
- Engine idle speed control
- Cruise control
- Cold start switch
- Trailer brake hand control
- Hazard warning switch
- Reading lamps
- Tool kit & jack
- Electric Horn
- Fluorescent Cab Lamp

FUSO HEAVY

8X4

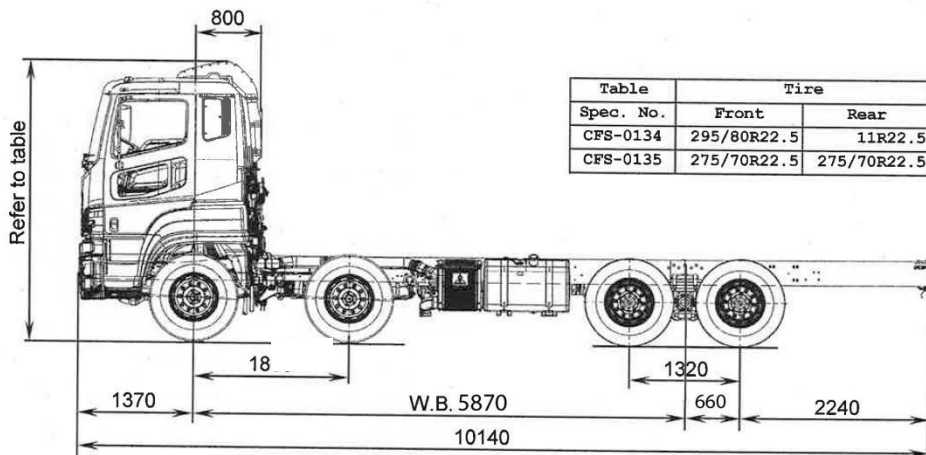

10.5 Chassis cab drawings

FS52SS3VFAA

FS52SS5VFAA

FS470S1

